

Side Channel Ring Blower (Ring Compressor)

INSTRUCTION MANUAL

RB20../ 30../ 40../ 50../ 60.. / 80.. SERIES

CONTENT	PAGE
1. SAFETY REQUIREMENT.....	1
2. INSTALLATION	2
3. OPERATION	6
4. MAINTENANCE	6
5. TROUBLE-SHOOTING	7
6. PARTS LIST.....	8



WARNING

1. This unit is designed to operate indoors , and is an environment that is a water-free and dust-free.
2. To avoid damaging this device, it must be absolutely prevented from dropping during transportation.
3. It's not allowed to install and operate this device before reading the instruction thoroughly.
4. For safety reason, please don't modify or repair the rotating part of this device.
5. The manufacturer has the right to modify the product without notice.
6. This unit is only a component, it must be installed in a machine or part of a machine which meets the terms of the machine directive 89/392/EEC. Commission will not occur until the end product or machinery conforms with the EN60204-1.

1. Safety requirements :



Warning

- 1.1 The maximum permissible ambient and air temperature at the intake is +40°C.
- 1.2 Max. permissible pressure in the device : 2 bar abs. At this pressure, the operation of the device may be considerably impaired.
- 1.3 All the works of transportation, installation, maintenance and troubleshooting must be executed by a responsible, qualified personnel.
- 1.4 This device must be set up according to this instruction manual.
- 1.5 The grounding wire must be connected well accordingly.
- 1.6 The lead wires as a conductor to the power supply should be properly sized and have strain relief to the wires at the connection terminals. If this is failed, electric shock and fire will be possible
- 1.7 While rotating, human body must keep away from the rotating portion such as the Cooling Fan and do not reach into the device through the intake or outlet.
- 1.8 Once the power electricity was interrupted, the power switch must be turned off immediately.
- 1.9 If the device couldn't accelerate up to its rated speed in 15 seconds from the power switch turned on, please turn off the power immediately and check it carefully.
- 1.10 The power supply must be turned off before moving, maintaining, or repairing this device. Please note that, due to rotating inertia, the device may continue running several minutes after power turned off.
- 1.11 These devices are only used to handle or conveying dust-free air, non- combustible, non-corrosive and non-explosive gases, vapors.
- 1.12 The intake must be properly sited and covered so that no dirt or solid particles can be sucked in.
- 1.13  When the device is operated at impermissible high pressure condition, a suitable pressure-relief valve must be used to prevent overheating of motor.
- 1.14 The End Cover is used to prevent contact and direct the cooling air flow, can not be removed; otherwise the motor will get overheating.
- 1.15 A Pilot type of Thermal Protector will be available according to customer's request. This protector should be externally connected with a Magnetic Switch which is used to control the power input ON/OFF.
- 1.16 This device is designed for continuous operation, in case of non-continuous running or high ambient temperature, checking suitability (maximum permissible temperature) with the representatives of manufacturer.

2. Installation

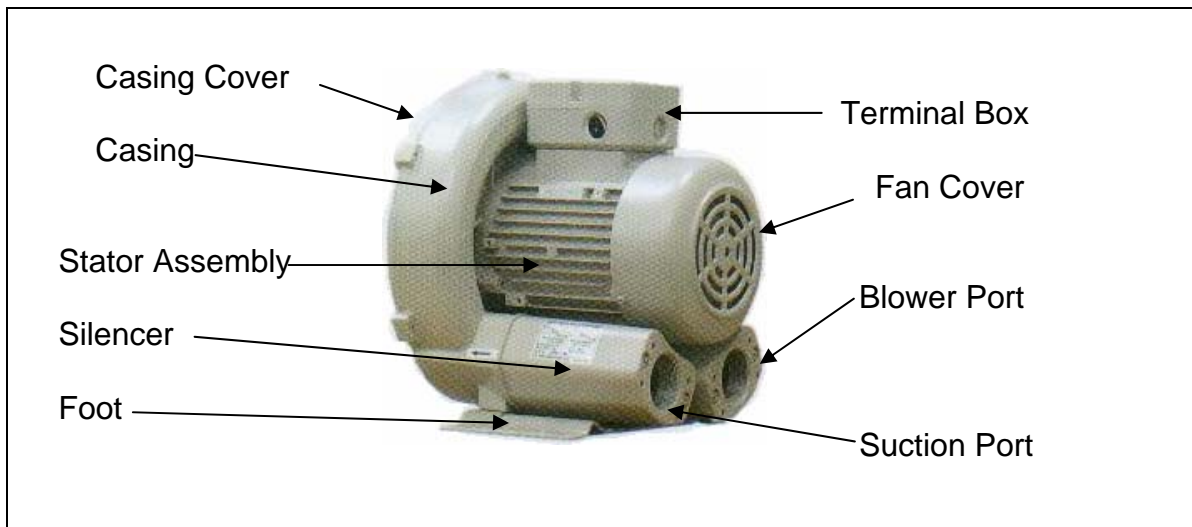

2.1 Application :

2.1.1 This device is used to handle non-combustible, non-corrosive and non-explosive gases and air. The ambient or gas temperature should be less than +40°C.

2.1.2 Dirt and solid particles must be filtered before entering intake of the device.



2.1.3 These devices must not be operated with closed intake or outlet.

2.1.4 The permissible pressure for continuous operation is shown in the nameplate "Max. Pressure" of the Ring Compressors.

2.2 Installation :

2.2.1 The Ring Compressors can be installed in any direction, but when mounted vertically, the motor side should be upward.

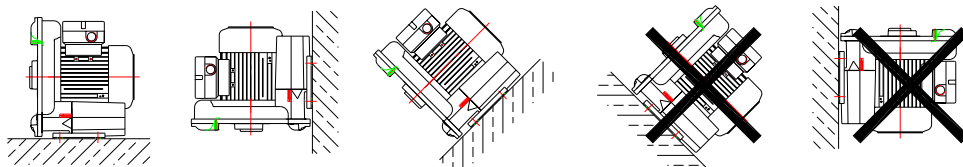

2.2.2 To avoid vibration, the unit must be mounted on a rigid base.

2.2.3 To ensure perfect cooling, the minimum clearances between the Front (Casing)Cover & Fan Cover and the walls should be for

ENGLISH

	Casing Cover	/	Fan Cover
RB20 / RB30 / RB40 / RB50	: 20 mm.	/	35 mm.
RB60	: 30 mm.	/	55 mm
RB80	: 40 mm	/	55 mm

Make sure too, no obstructions in the cooling air flow system.

2.2.4 Any flammable materials must be kept away from the unit.

2.2.5 Air and gases should be filtered before entering the intake by an intake or inline filter.

2.2.6 To reduce noise, additional silencers are optional.

2.3 Electric Connection :



WARNING: No connecting work is allowed before the electric power disconnected.

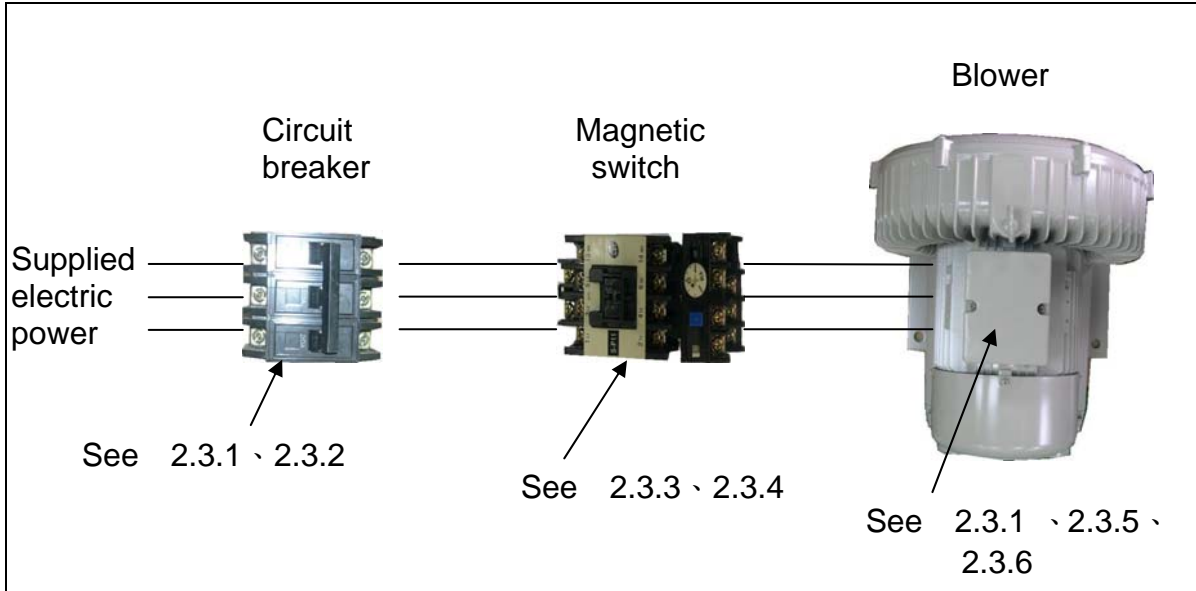

2.3.1 The supplied power voltage must be the same as the rating stated on the name-plate.

2.3.2 Select the correct circuit breaker to match the motor's rated current.

2.3.3 We recommended when using the magnetic switch , the setting value of electric current is the motor's rated current of 0.91 times.

2.3.4 Thermal protectors connection :

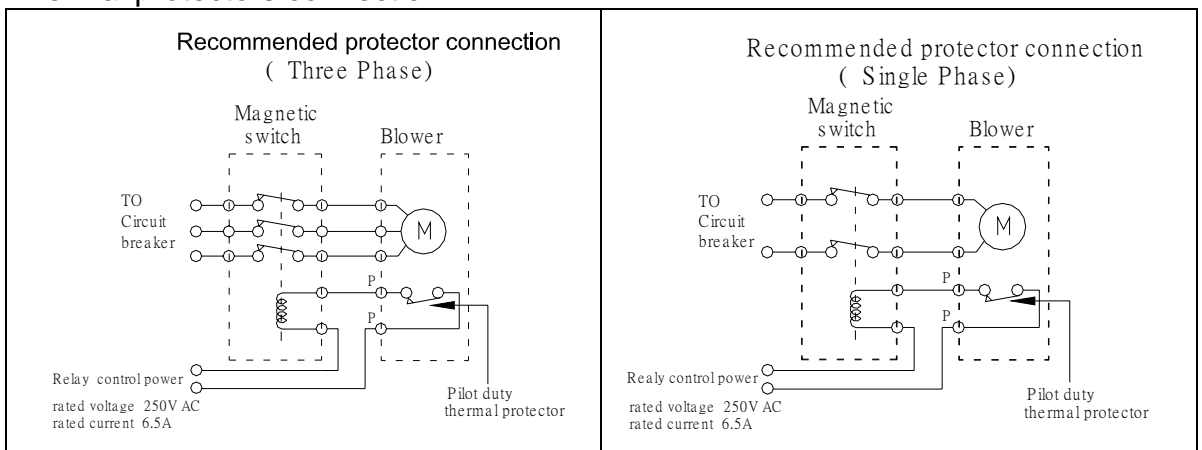

2.3.5 The protective earth conductor must be connected to the grounding terminal.

2.3.6 The lead wires must be connected according to the diagram attached on the terminal box.

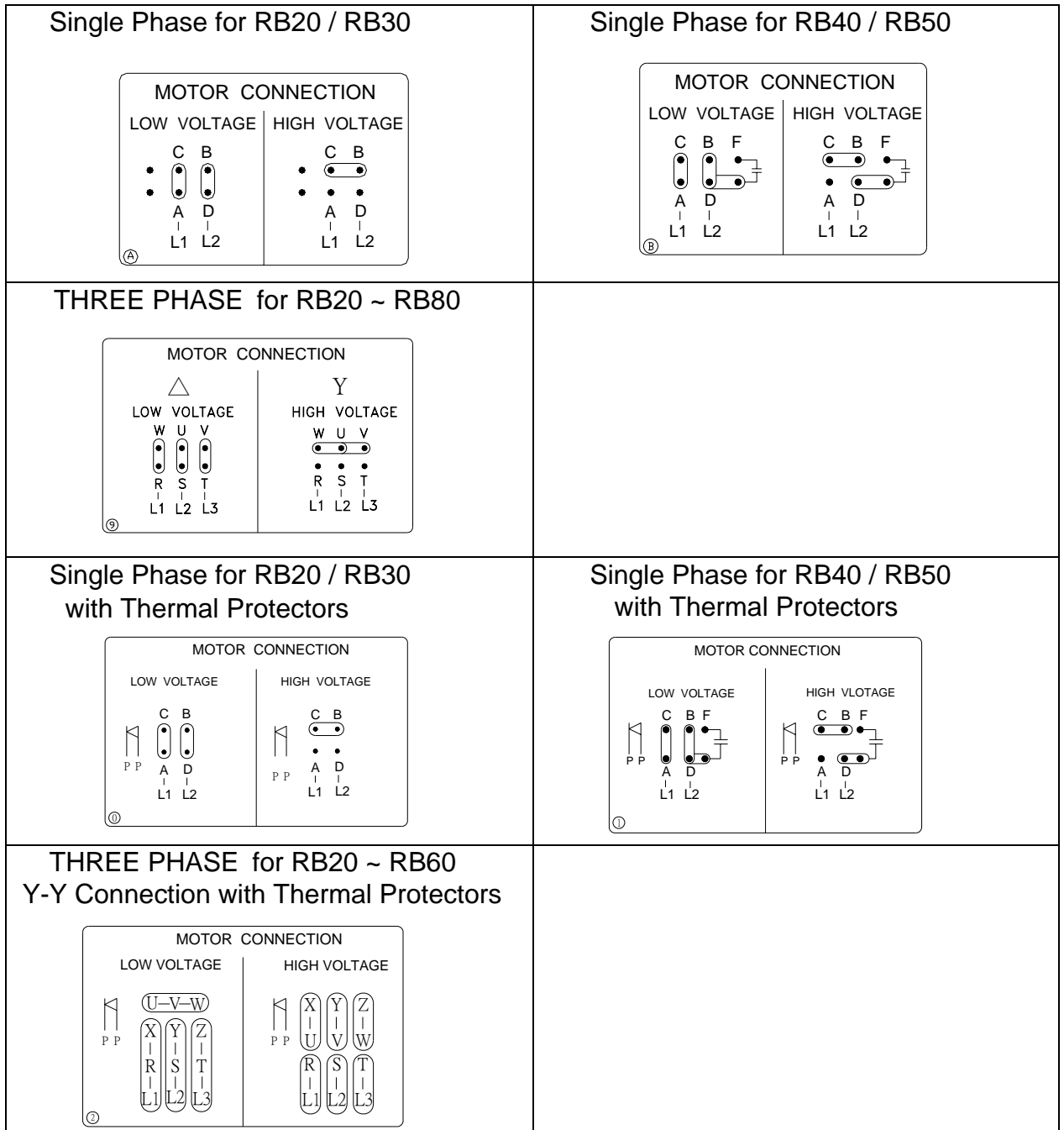

3. Operation:

- 3.1 These devices must be rotated in the “Arrow“ direction marked on the casing.
- 3.2 For three phases, changing direction may be done by exchanging any two of the lines of power input.
- 3.3 These devices should be operated with the air flow and pressure within the permitted range listed in the nameplate of the Ring Compressors.
- 3.4 To avoid operating over the permitted range, the pressure or vacuum relief is recommended.

4. Maintenance:



WARNING: No maintaining work is allowed before the electric power off.

- 4.1 To maintain a good cooling performance, it's necessary to clean the inside and outside of the Fan Cover to remove dirt and dust in a period of time; otherwise the motor might be burnt.
- 4.2 The bearing, oil seal and silencers are subject to wear; these parts should be replaced with new ones as necessary.

5. Trouble-shooting:

Fault	Cause	Remedy
Motor does not run and without humming noise	<ul style="list-style-type: none"> . No power. . Two power cords opened. . Power switch or starter defected. . Motor winding opened. . Protector or protecting circuit opened. 	<ul style="list-style-type: none"> . Supply power. . Check the power cord. . Change the power switch or starter. . Change the motor winding. . Change the protector or fix the protecting circuit.
Motor does not run with humming noise	<ul style="list-style-type: none"> . One power cord opened. . Power switch or starter defected. . Motor winding opened. . Bearing defected. . Impeller jammed by foreign material. . Impeller jammed against casing or cover. . Capacitor (single phase) defected. 	<ul style="list-style-type: none"> . Check the power cord. . Change the power switch or starter. . Change a new motor winding. . Change bearing. . Clean the impeller. . Adjust the impeller. . Change a new capacitor.
Normal running, over heating, protector or protection circuit trips repeatedly	<ul style="list-style-type: none"> . Motor overloaded . Short-circuit in the winding. . Impeller jammed. 	<ul style="list-style-type: none"> . Reduce operating pressure, Install the pressure or vacuum relief, clean filter \ fan cover \ silencer or pipes. . Change a new motor winding. . Clean or adjust the impeller.
Weak vacuum	<ul style="list-style-type: none"> . Compressor too small . Wrong power frequency . Wrong direction of rotation . Oil seal defected . Air leakage in the system 	<ul style="list-style-type: none"> . Change a larger compressor. . Adjust power frequency. . Change direction. . Change a new oil seal. . Check the system and make air- tight.
Abnormal noise	<ul style="list-style-type: none"> . Silencer dirty . Bearing lubrication insufficient 	<ul style="list-style-type: none"> . Clean silencer. . The old grease should be removed and be recharged with fresh grease, or be replaced a new bearing.

ENGLISH

6. Parts List

Fig. No.	Name of part	RB20..	RB30..
		1-stage	1-stage
1-1	Bolt	✓	✓
1-2	Casing cover	✓	✓
2-1	Bolt	✓	✓
2-2	Washer	✓	✓
2-3	Plate retaining	✓	✓
2-4	Impeller	✓	✓
2-5	Shim assembly	✓	✓
2-6	Collar	✓	✓
3-1	Screw	✓	✓
3-2	Bearing cover	✓	✓
3-3	Shaft seal	✓	✓
3-4	Casing	✓	✓
4-1	Stator assembly	✓	✓
4-2	Bolt	✓	✓
4-3	End housing	✓	✓
4-4	Fan	✓	✓
4-5	Fan cover	✓	✓
4-6	Screw	✓	✓
4-7	Nut	✓	✓
4-8	Spring washer	✓	✓
4-9	Screw	✓	✓
4-10	Nut	✓	✓
5-1	Bearing	✓	✓
5-2	Key	✓	✓
5-3	Motor rotor	✓	✓
5-4	Bearing	✓	✓
5-5	Wave washer	✓	✓
6-1	Capacitor cover	only 1 φ	only 1 φ
6-2	Screw	only 1 φ	only 1 φ
6-3	Screw	only 1 φ	only 1 φ
6-4	Clip	only 1 φ	only 1 φ
6-5	Sleeve	only 1 φ	only 1 φ
6-6	Capacitor	only 1 φ	only 1 φ
6-7	Bushing	only 1 φ	only 1 φ
7-1	Cover for terminal box	✓	✓
7-2	Gasket	✓	✓
7-3	Gasket	✓	✓
7-4	Under part of terminal box	✓	✓
7-5	Spring washer	✓	✓
7-6	Screw for earth	✓	✓
7-7	Bushing	✓	✓
7-8	Screw	✓	✓
7-9	Terminal board	✓	✓
7-10	Screw	✓	✓
7-11	Nut	✓	✓
7-12	Terminal plate	✓	✓
7-13	Terminal clip	✓	✓
7-14	Screw	✓	✓
8-1	Silencer assembly	✓	✓
8-2	Silencer retaining	✓	✓
8-3	End cover	✓	✓
8-4	Screw	✓	✓
8-5	Gasket	✓	✓
8-6	Threaded flange	✓	✓
8-7	Bolt	✓	✓
8-8	Hose flange	✓	✓

Order example: RB20-5B3, Fig.No.5-1, Q'ty: 2

ENGLISH

Fig. No.	Name of part	RB30....-Z		RB40..		RB50..	
		1-stage	2-stage	1-stage	2-stage	1-stage	2-stage
1-1	Bolt	✓	✓	✓	✓	✓	✓
1-2	Casing cover	✓	✓	✓	✓	✓	✓
1-3	Screw	✓	✓	✓	✓	✓	✓
1-4	Washer	✓	✓	✓	✓	✓	✓
1-5	O-ring	✓	✓	✓	✓	✓	✓
2-1	Bolt	✓	✓	✓	✓	✓	✓
2-2	Spring washer	✓	✓	✓	✓	✓	✓
2-3	Plate retaining	✓	✓	✓	✓	✓	✓
2-4	Bearing	✓	✓	✓	✓	✓	✓
2-5	Bearing cover	✓	✓	✓	✓	✓	✓
2-6	Impeller	✓	✓	✓	✓	✓	✓
2-7	Collar	N/A	N/A	N/A	N/A	✓	✓
2-8	Centre casing	N/A	✓	N/A	✓	✓	✓
2-9	Sleeve	N/A	✓	N/A	✓	✓	✓
2-10	Cowl	N/A	✓	N/A	✓	N/A	✓
3-1	Casing	✓	✓	✓	✓	✓	✓
3-2	Eyebolt	N/A	N/A	N/A	N/A	✓	✓
3-3	Felt ring	✓		✓		✓	✓
3-4	Shaft seal	✓		✓		✓	✓
3-5	Square nut	✓		✓		N/A	N/A
3-6	Sleeve	N/A	N/A	N/A	N/A	✓	✓
3-7	Foot	✓	✓	✓	✓	✓	✓
3-8	Square nut	✓	✓	✓	✓	✓	✓
3-9	Bolt	✓	✓	✓	✓	✓	✓
3-10	Spring washer	✓	✓	✓	✓	✓	✓
3-11	Bolt	✓	✓	✓	✓	✓	✓
3-12	Bracket	N/A	N/A	N/A	N/A	✓	✓
3-13	Bolt	N/A	N/A	N/A	N/A	✓	✓
4-1	Stator assembly	✓	✓	✓	✓	✓	✓
4-2	End housing	✓	✓	✓	✓	✓	✓
4-3	Bolt	✓	✓	✓	✓	✓	✓
4-4	Bolt	✓	✓	✓	✓	✓	✓
4-5	Fan	✓	✓	✓	✓	✓	✓
4-6	Fan cover	✓	✓	✓	✓	✓	✓
4-7	Screw	✓	✓	✓	✓	✓	✓
4-8	Nut	N/A	N/A	N/A	N/A	N/A	N/A
4-9	Nut	N/A	N/A	N/A	N/A	N/A	N/A
4-10	Flange	N/A	✓	N/A	✓	✓	✓
4-11	Bolt	N/A	✓	N/A	✓	✓	✓
5-1	Key	✓	✓	✓	✓	✓	✓
5-2	Motor rotor	✓	✓	✓	✓	✓	✓
5-3	Bearing	✓		✓		✓	✓
5-4	Wave washer	✓		✓		✓	✓
6-1	Cable gland	only 1 φ	only 1 φ	only 1 φ	only 1 φ	only 1 φ	N/A
6-2	Screw	only 1 φ	only 1 φ	only 1 φ	only 1 φ	only 1 φ	N/A
6-4	Clip	only 1 φ	only 1 φ	only 1 φ	only 1 φ	only 1 φ	N/A
6-6	Capacitor assembly	only 1 φ	only 1 φ	only 1 φ	only 1 φ	only 1 φ	N/A
7-1	Cover for terminal box	✓	✓	✓	✓	✓	✓
7-2	Screw	✓	✓	✓	✓	✓	✓
7-3	Gasket	✓	✓	✓	✓	✓	✓
7-4	Terminal board	✓	✓	✓	✓	✓	✓
7-5	Nut	✓	✓	✓	✓	✓	✓
7-6	Terminal plate	✓	✓	✓	✓	✓	✓
7-7	Screw for earth	✓	✓	✓	✓	✓	✓
7-8	Spring washer	✓	✓	✓	✓	✓	✓
7-9	Screw	✓	✓	✓	✓	✓	✓
7-10	Under part of terminal box	✓	✓	✓	✓	✓	✓
7-11	Gasket	✓	✓	✓	✓	✓	✓
7-12	Screw	✓	✓	✓	✓	✓	✓
7-13	Nut	✓	✓	✓	✓	✓	✓
7-14	Terminal clip	✓	✓	✓	✓	✓	✓
7-15	Screw	✓	✓	✓	✓	✓	✓
7-16	Plug	✓	✓	✓	✓	✓	✓
8-1	Gasket	✓	✓	✓	✓	✓	✓

ENGLISH

8-2	Silencer retaining	✓	✓	✓	✓	✓	✓
8-3	Silencer assembly	✓	✓	✓	✓	✓	✓
8-4	Silencer casing	✓	✓	✓	✓	✓	✓
8-5	Bolt	✓	✓	✓	✓	✓	✓
8-6	Bolt	✓	✓	✓	✓	✓	✓
8-7	Threaded flange	N/A	N/A	N/A	N/A	✓	✓
8-8	Hose flange	✓	✓	✓	✓	✓	✓
8-9	Gasket	✓	✓	✓	✓	✓	✓
8-10	Gasket	N/A	✓	N/A	✓	N/A	✓
8-11	Flange	N/A	✓	N/A	✓	N/A	✓
8-12	S-pipe, intake side	N/A	✓	N/A	N/A	N/A	N/A
8-13	S-pipe, discharge side	N/A	✓	N/A	N/A	N/A	N/A
8-14	Bolt	N/A	✓	N/A	N/A	N/A	N/A
8-15	Cover, discharge side	N/A	✓	N/A	N/A	N/A	N/A
8-16	Bolt	N/A	✓	N/A	N/A	N/A	N/A

ENGLISH

Fig. No.	Name of part	RB60..		RB80..	RB80..-Z	
		1-stage	2-stage	1-stage	1-stage	2-stage
1-1	Bolt	✓	✓		✓	✓
1-2	Casing cover	✓	✓		✓	✓
1-3	Screw	✓	✓		✓	✓
1-4	Washer	✓	✓		✓	✓
1-5	O-ring	✓	✓	N/A	N/A	N/A
2-1	Bolt	✓	✓		✓	✓
2-2	Spring washer	✓	✓		✓	✓
2-3	Plate retaining	✓	✓		✓	✓
2-4	Bearing	✓	✓		✓	✓
2-5	Bearing cover	✓	✓		✓	✓
2-6	Impeller	✓	✓		✓	✓
2-7	Collar	✓	✓	N/A	✓	✓
2-8	Centre casing	✓	✓		✓	✓
2-9	Sleeve	✓	✓		✓	✓
2-10	Cowl	N/A	✓	N/A	N/A	N/A
3-1	Casing	✓	✓		✓	✓
3-2	Eyebolt	✓	✓		✓	✓
3-3	Felt ring	✓	✓	N/A	✓	✓
3-4	Shaft seal	✓	✓		✓	✓
3-5	Square nut	N/A	N/A	N/A	N/A	N/A
3-6	Sleeve	✓	✓		✓	✓
3-7	Foot	✓	✓		✓	✓
3-8	Square nut	✓	✓	N/A	✓	✓
3-9	Bolt	✓	✓		✓	✓
3-10	Spring washer	✓	✓		✓	✓
3-11	Bolt	✓	✓		✓	✓
3-12	Bracket	N/A	N/A		N/A	N/A
3-13	Bolt	N/A	N/A		N/A	N/A
4-1	Stator assembly	✓	✓		✓	✓
4-2	End housing	✓	✓		✓	✓
4-3	Bolt	✓	✓		✓	✓
4-4	Bolt	✓	✓		✓	✓
4-5	Fan	✓	✓		✓	✓
4-6	Fan cover	✓	✓		✓	✓
4-7	Screw	✓	✓		✓	✓
4-8	Nut	✓	✓		✓	✓
4-9	Nut	✓	✓		✓	✓
4-10	Flange	✓	✓		✓	✓
4-11	Bolt	✓	✓		✓	✓
5-1	Key	✓	✓		✓	✓
5-2	Motor rotor	✓	✓		✓	✓
5-3	Bearing	✓	✓		✓	✓
5-4	Wave washer	✓	✓		✓	✓
6-1	Cable gland	N/A	N/A	N/A	N/A	N/A
6-2	Screw	N/A	N/A	N/A	N/A	N/A
6-4	Clip	N/A	N/A	N/A	N/A	N/A
6-6	Capacitor assembly	N/A	N/A	N/A	N/A	N/A
7-1	Cover for terminal box	✓	✓		✓	✓
7-2	Screw	✓	✓		✓	✓
7-3	Gasket	✓	✓		✓	✓
7-4	Terminal board	✓	✓		✓	✓
7-5	Nut	✓	✓		✓	✓
7-6	Terminal plate	✓	✓		✓	✓
7-7	Screw for earth	✓	✓		✓	✓
7-8	Spring washer	✓	✓		✓	✓
7-9	Screw	✓	✓		✓	✓
7-10	Under part of terminal box	✓	✓		✓	✓
7-11	Gasket	✓	✓		✓	✓
7-12	Screw	✓	✓		✓	✓
7-13	Nut	✓	✓		✓	✓
7-14	Terminal clip	✓	✓		✓	✓
7-15	Screw	✓	✓		✓	✓
7-16	Plug	✓	✓		✓	✓
8-1	Gasket	✓	✓		✓	✓
8-2	Silencer retaining	✓	✓		✓	✓

ENGLISH

8-3	Silencer assembly	✓	✓		✓	✓
8-4	Silencer casing	✓	✓		✓	✓
8-5	Bolt	✓	✓		✓	✓
8-6	Bolt	✓	✓		✓	✓
8-7	Threaded flange	✓	✓		✓	✓
8-8	Hose flange	✓	✓	N/A	N/A	N/A
8-9	Gasket	✓	✓	✓	✓	✓
8-10	Gasket	N/A	✓	N/A	N/A	✓
8-11	Flange	N/A	✓	N/A	N/A	✓
8-12	S-pipe, intake side	N/A	✓	N/A	N/A	✓
8-13	S-pipe, discharge side	N/A	✓	N/A	N/A	✓
8-14	Bolt	N/A	✓	N/A	N/A	✓
8-15	Cover, discharge side	N/A	✓	N/A	N/A	✓
8-16	Bolt	N/A	✓	N/A	N/A	✓

1-stage

RB20..

RB30..

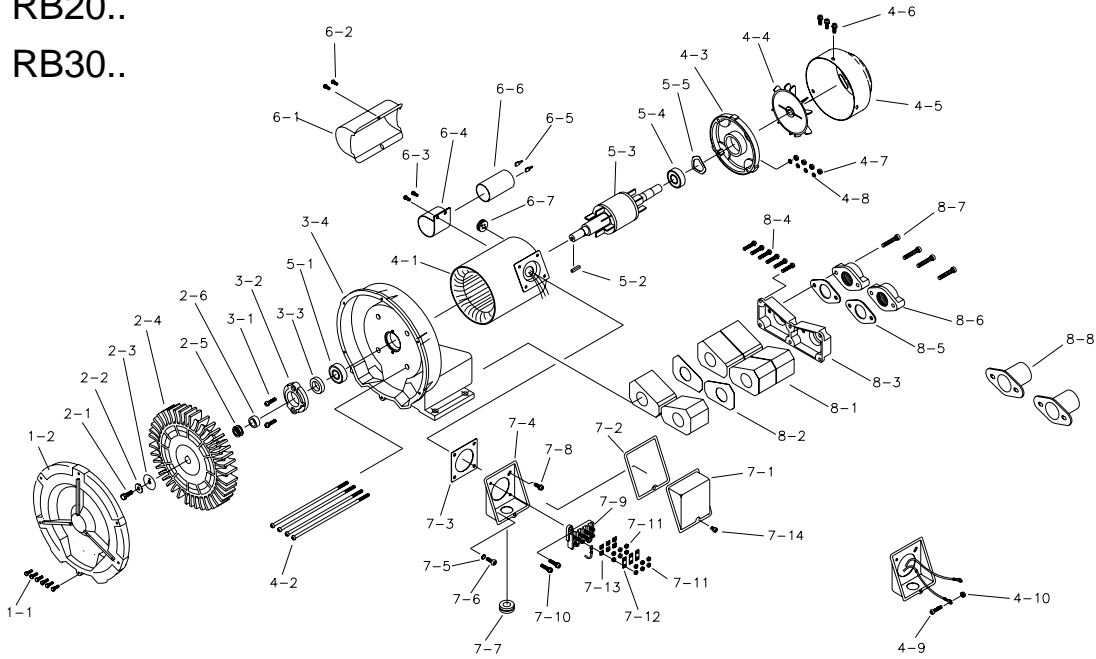

1-stage

RB30..-Z

RB40..

RB50..

RB60..

RB80..

RB80..-Z

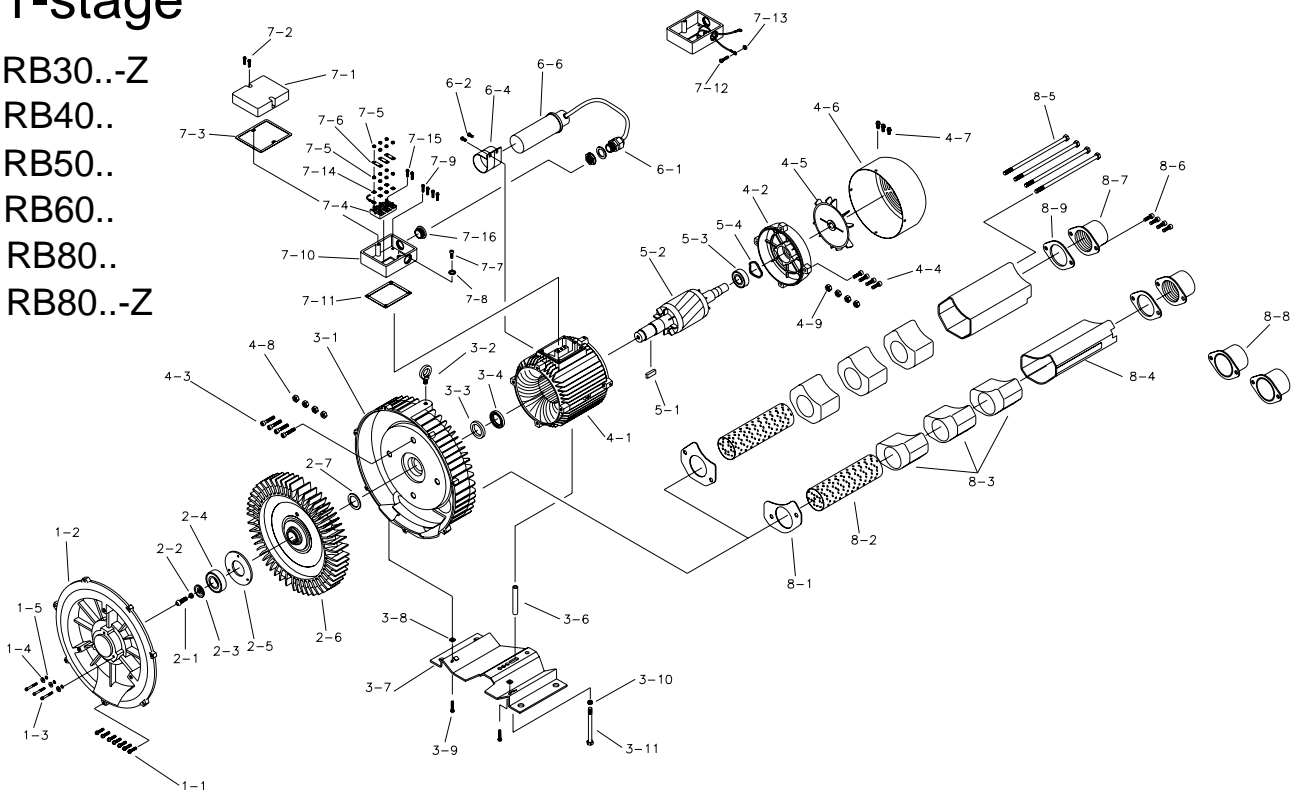

2-stage

RB30-1..

RB40-1..

RB50-1..

RB60-1..

RB60-4..

RB80-1..

RB80-4..

